

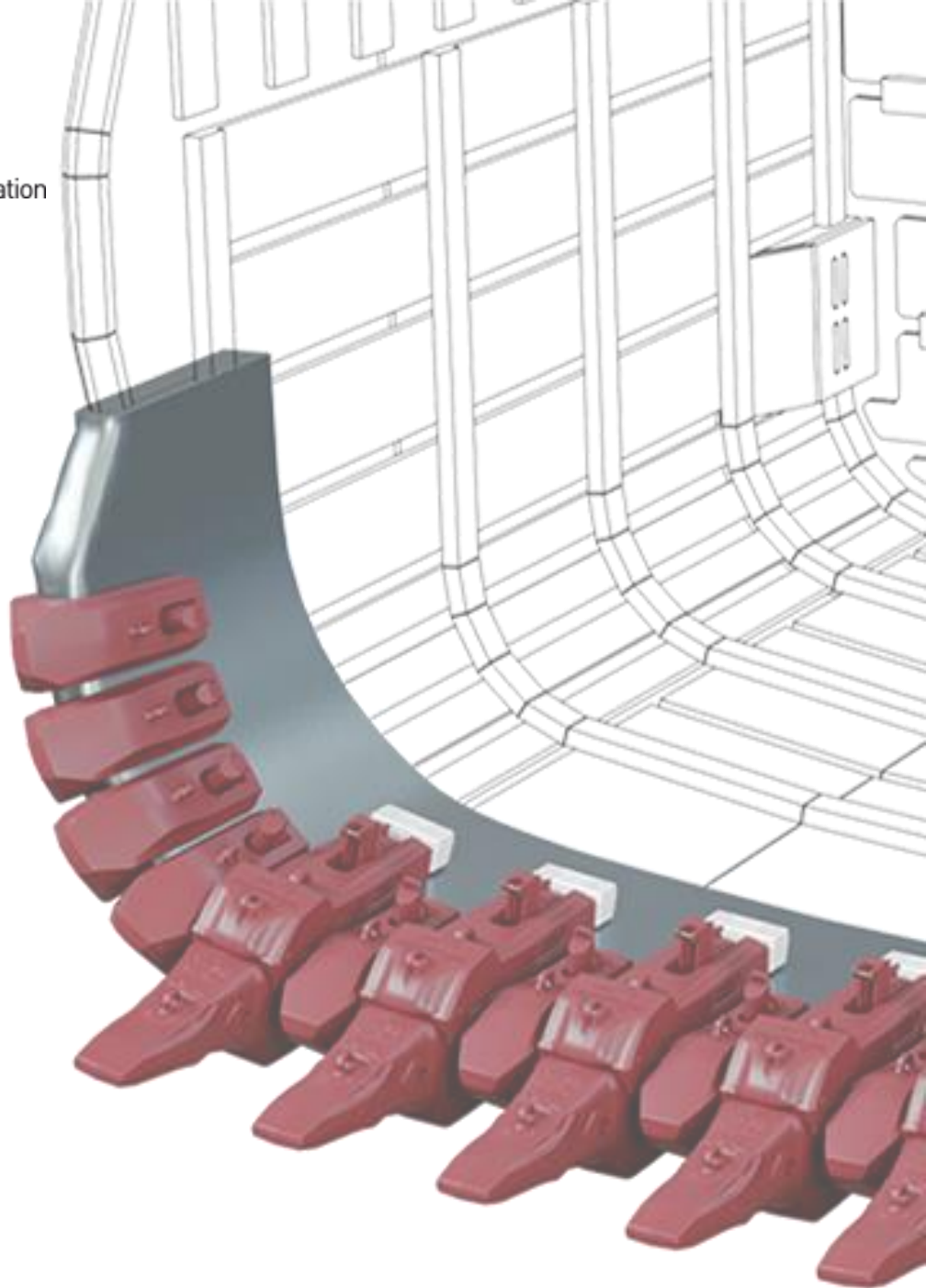

MTG

No limits innovation



INS.3.7.4

Lower Wing Shroud Curved + Hammerless 2- part Locking H2

Installation procedure

DISCLAIMER

© MTG, all rights reserved

The brands identified with an asterisk do not belong to METALOGENIA S.A. and this organization refers to them only to identify the destination of its products, without there being any relationship between METALOGENIA S.A. and the legitimate owners of any such brands.

Copy right: It is strictly forbidden for any person not belonging to MTG to distribute all or any part of the material set out in this document unless they are authorized to do so.

Liability: To ensure the correct use and handling of the MTG products without risk, please carefully read the corresponding service instructions set out on the MTG website. MTG will not be held liable for damages, loss, injury, or death arising from incorrect use or failure to heed the provisions of this guide. Similarly, MTG will not be held liable for damages caused due to the faulty installation or handling of its products. MTG likewise declines all liability for recommendations related to the use or handling of MTG products set out in documents not expressly authorized by MTG.

1. SAFETY

The practices described in this manual can be taken as guidelines for operating safely in many conditions and in addition to the safety standards that are current and enforceable in your area or region.

Your safety and the safety of third parties is the result of putting into practice your knowledge of the correct operational procedures.

Attention, when performing the work described in these instructions, always work safely and use the personal protection elements required to minimize or avoid injury. Always wear:



**HARD
HAT**



**SAFETY
GLASSES**



**EAR
PROTECTION**



**STEEL TOED
BOOTS**



**PROTECTION
GLOVES**

To avoid eye injury, always wear safety goggles or a protective mask when using any equipment, hammer or similar tool. When equipment is under pressure or when objects are struck, chips or other debris can be thrown out. Make sure no one gets hurt by the debris that is fired before applying pressure or hitting an object. Wear eye protection that complies with ANSI Z87.1 and OSHA standards. Also wear hearing protection and gloves.

Lifting a heavy object can cause serious or fatal injury. DO NOT exceed the maximum rated capacity of lifting and positioning devices: Stay away from the area under a suspended load.



**LIFTING
LUG**

Make sure that the chain is not damaged and that the load is always balanced.

2. WING SHROUD INSTALLATION

CAUTION: Installation of MTG products for rope shovels may require reconstructive work on the lip, such as welding and grinding, to return it to its original geometry and ensure proper fit and performance.



To perform the reconstruction/recalibration of lips, it is mandatory to follow the MTG reparation instructions for rope shovels which describe the proper procedures for recovering the lip geometry by using MTG gauges. Please contact technical.services@mtg.es for further information.

2.1 Mount the wing shroud onto its station ensuring contact between the wing shroud and the **curved edge of the lip**. Ensure the housing for the locking mechanism is on the **outside of the dipper**.

DIPPER SIDE VIEW

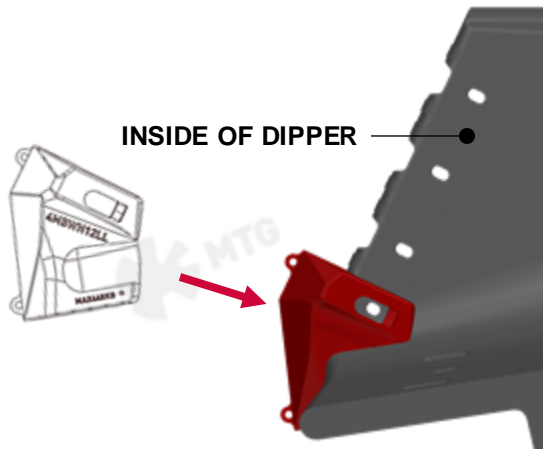

DIPPER FRONT VIEW

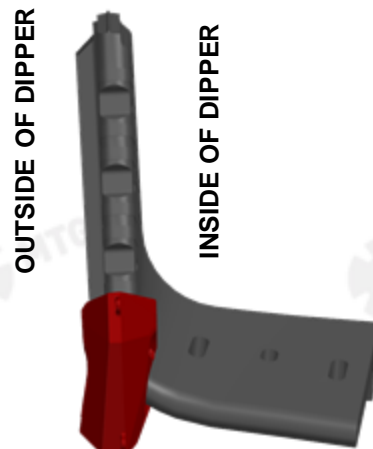

LATERAL CONTACT AREAS (WING)

FRONTAL CONTACT AREA (WING)

FRONTAL CONTACT AREA (LIP)

INSIDE OF DIPPER

CONTACT AREAS ON LIP AND WING

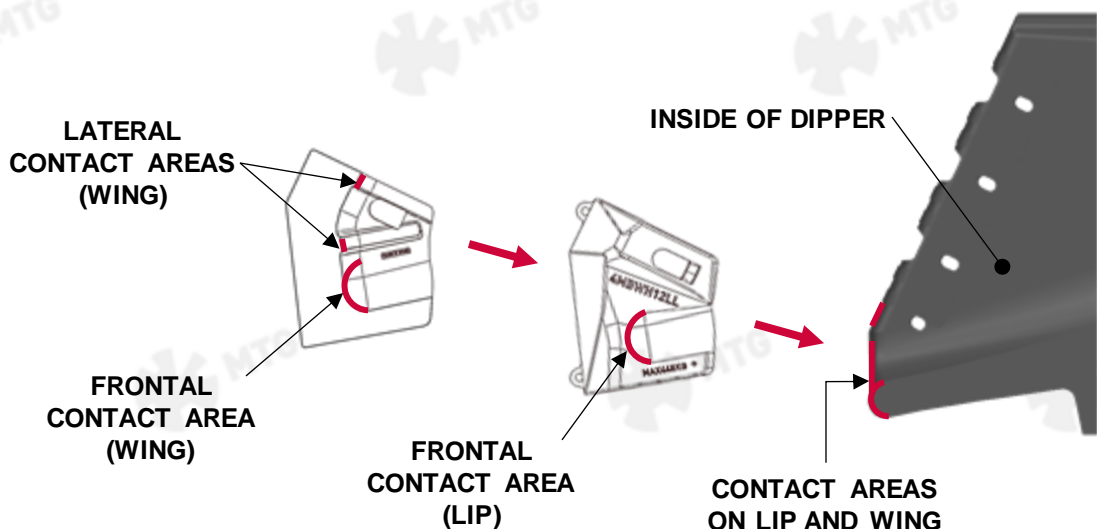

2.2 Use the handle on the C-Clamp to install it from the **inside of the dipper**.

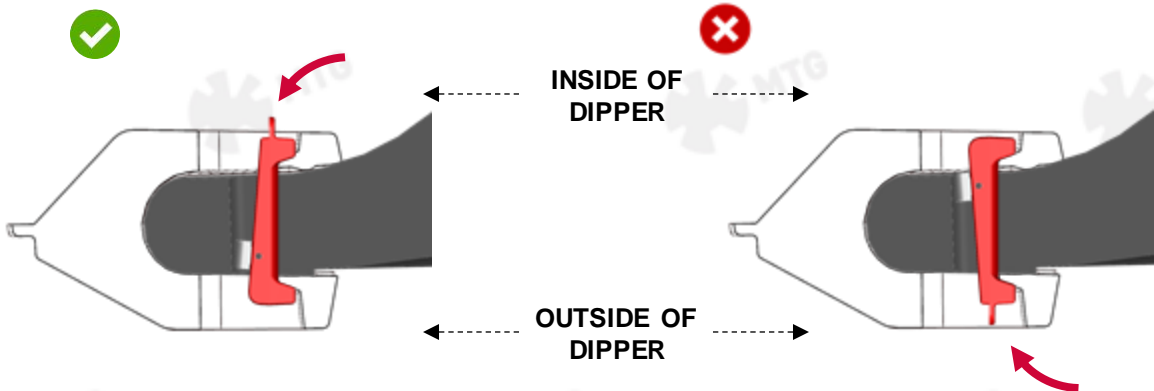

2.3 Insert the torque pin into the wedge and then insert the wedge and torque pin together into place between the lip and the C-Clamp as shown below. Tighten the torque pin to a torque of 540 Nm [400 lbf-ft] using an impact gun and a 19 mm [3/4"] hex socket.

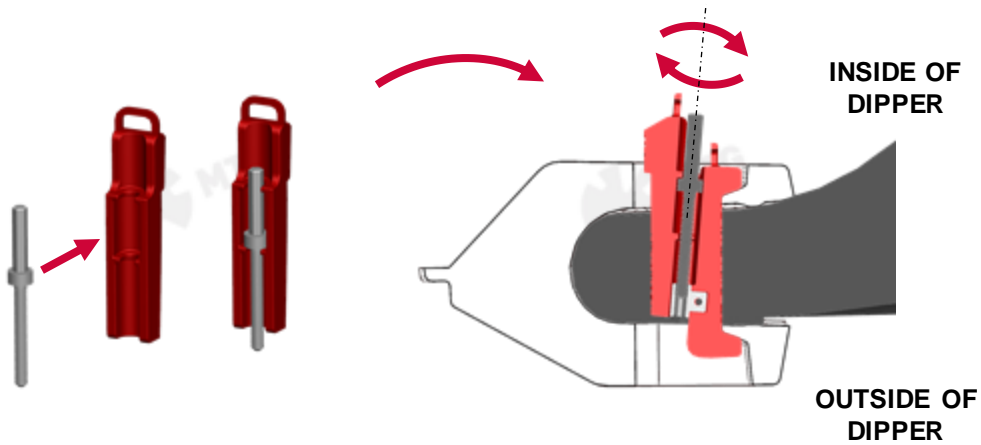

2.4 The wedge should protrude between 75 mm and 87.5 mm [3" and 3-1/2"] above the lip shroud. If the wedge protrudes more than this, it could mean that either the lip shroud is not seated properly or that there is deformation in the lip shroud station hole which needs to be repaired.

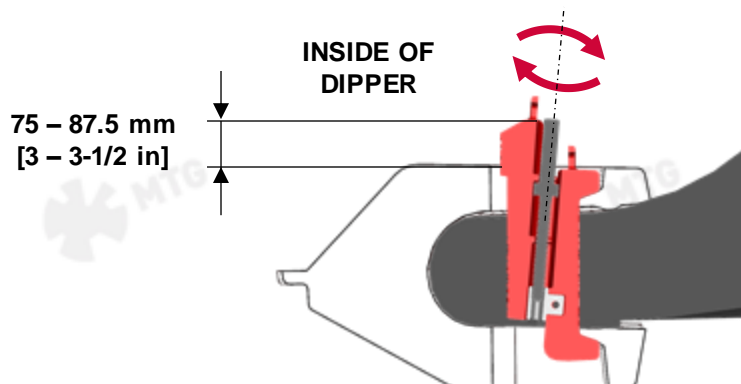

- 2.5** If after installation the wedge sits at or below the height of the C-Clamp, remove it and use an oversize wedge instead. If after installing an oversize wedge the problem persists this means that the lip needs to be rebuilt.

INSIDE OF DIPPER

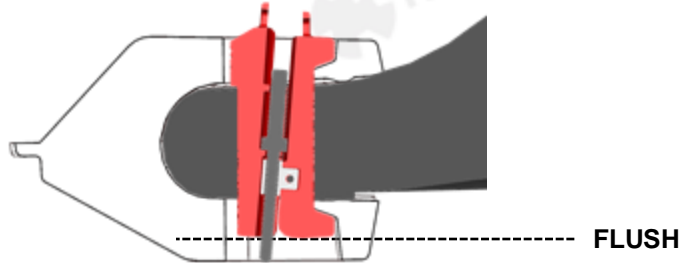

OUTSIDE OF DIPPER

3. WING SHROUD REMOVAL

3.1 Place the dipper in a safe position to access the wedge from the inside of the dipper.

3.2 Use an impact gun and a 19 mm [3/4"] hex socket to loosen the torque pin. This will cause the torque pin to pull the wedge up and release pressure on the locking mechanism. Remove the wedge and torque pin. A long socket or an extension may be required if the torque pin is sitting too low in the locking mechanism.

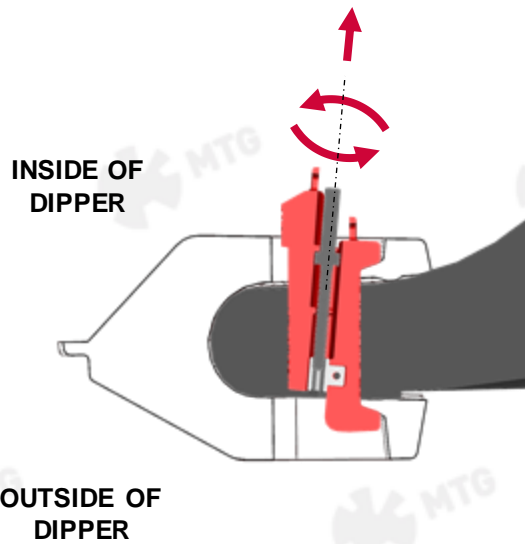

3.3 Extract the C-Clamp and remove the wing shroud.



Service Instructions

The latest welding recommendations and assembly / disassembly instructions can be found online:

www.mtgcorp.com/manuals

Please contact Technical Services in case of questions:

technical.services@mtg.es



MTG HEADQUARTERS

Carrer d'Àvila, 45
08005 Barcelona (Spain)
(+34) 93 741 70 00
info@mtg.es

MTG NORTH AMERICA

4740 Consulate Plaza Drive
Houston, TX 77032 (USA)
+1 (281) 872 1500
info@mtgcorp.us

MTG AUSTRALIA

16 – 18 Thorpe Close
Welshpool, WA, 6106 (AUS)
+61 8 6248 6513
Info.australia@mtg.es