



MTG

No limits innovation



INS.3.3.1

TERRA Cast Lip Lower Wing Shroud CLT

Installation procedure

DISCLAIMER

© MTG, all rights reserved

The brands identified with an asterisk do not belong to METALOGENIA S.A. and this organization refers to them only to identify the destination of its products, without there being any relationship between METALOGENIA S.A. and the legitimate owners of any such brands.

Copy right: It is strictly forbidden for any person not belonging to MTG to distribute all or any part of the material set out in this document unless they are authorized to do so.

Liability: To ensure the correct use and handling of the MTG products without risk, please carefully read the corresponding service instructions set out on the MTG website. MTG will not be held liable for damages, loss, injury, or death arising from incorrect use or failure to heed the provisions of this guide. Similarly, MTG will not be held liable for damages caused due to the faulty installation or handling of its products. MTG likewise declines all liability for recommendations related to the use or handling of MTG products set out in documents not expressly authorized by MTG.

1. SAFETY

The practices described in this manual can be taken as guidelines for operating safely in many conditions and in addition to the safety standards that are current and enforceable in your area or region.

Your safety and the safety of third parties is the result of putting into practice your knowledge of the correct operational procedures.

Attention, when performing the work described in these instructions, always work safely and use the personal protection elements required to minimize or avoid injury. Always wear:



To avoid eye injury, always wear safety goggles or a protective mask when using any equipment, hammer or similar tool. When equipment is under pressure or when objects are struck, chips or other debris can be thrown out. Make sure no one gets hurt by the debris that is fired before applying pressure or hitting an object. Wear eye protection that complies with ANSI Z87.1 and OSHA standards. Also wear hearing protection and gloves.

Lifting a heavy object can cause serious or fatal injury. DO NOT exceed the maximum rated capacity of lifting and positioning devices: Stay away from the area under a suspended load.



LIFTING LUG

Make sure that the chain is not damaged and that the load is always balanced.

2. WELDING

Following is a quick reference on consumables that can be used to weld MTG products. For a complete reference on welding procedures, refer to the document entitled "General welding recommendations".

WELDING UNALLOYED FILLER CONSUMABLES

PROCESS	EN CLASS	AWS CLASS
SMAW	EN ISO 2560-S E42X	E70X ACCORDING TO A5.1 OR EQUIVALENT UNDER A5.5
	EN ISO 14341-A G42X	E70C-X ACCORDING TO A5.18 OR EQUIVALENT UNDER A5.28
GMAW	EN ISO 14341-A G46X	E70S-X ACCORDING TO A5.18 OR EQUIVALENT UNDER A5.28
	EN ISO 16834-A T42X	E7XT-X ACCORDING TO A5.20 OR EQUIVALENT UNDER A5.29
FCAW	EN ISO 16834-A T42X	E7XT-X ACCORDING TO A5.20 OR EQUIVALENT UNDER A5.29

WELDING AUSTENITIC STAINLESS FILLER CONSUMABLES

PROCESS	AWS CLASS
SMAW	E307-X ACCORDING TO A5.4
	ER307T-X ACCORDING TO A5.22
GMAW	ER307 ACCORDING TO A5.9
	307-X ACCORDING TO A5.22
FCAW	307-X ACCORDING TO A5.22

NOTE: "X" MAY STAND FOR ONE OR SEVERAL CHARACTERS

3. IMPORTANT

Read the full document prior to start any operation since there may be some steps which may require previous verifications/operations. 

These instructions are a generic procedure for all MTG Lower wing shrouds for TERRA Cast Lips, regardless of size. For this reason, it is possible that the images contained in these instructions may differ from the parts to be installed in each case.

In order to ensure a good behavior of these shrouds during work, a correct positioning of the weld-on bases is required. On Terra lips, the weld-on bases for lower wing shrouds will only be installed at the **outer face of the lip**.

4. WELD-ON BASE POSITIONING

- 4.1** Insert the shroud into position, making sure it is fully contacting the front of the lip side. The shroud, must also rest in the indicated support area.

For this step, it is also necessary to install the intermediate adapter or the tooth of that position to ensure that there is some gap between parts to allow the removal of the shroud.

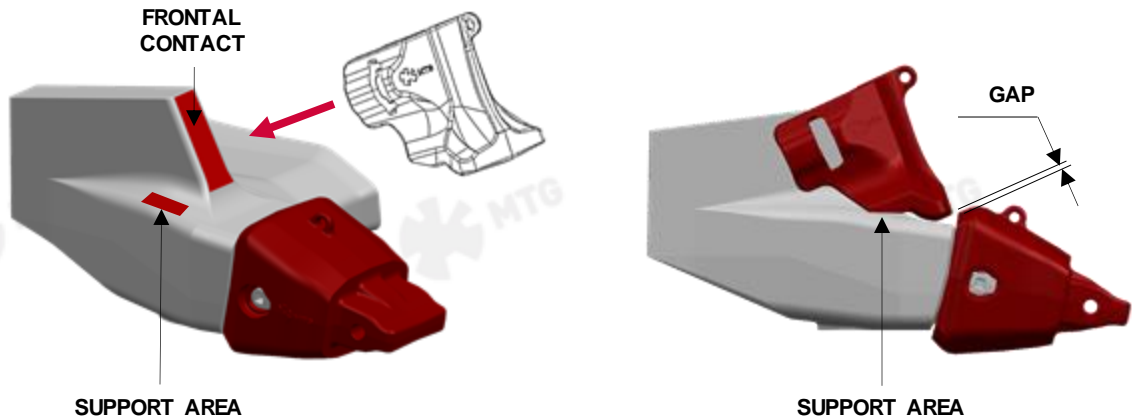

- 4.2** Insert the weld-on base at the outside of the lip, through the guides of the shroud until it is approximately flush with it.



- 4.3** Insert the mechanical block into its housing, making sure that the "FRONT" engraving is facing away from the bucket. At this time, the weld-on base can no longer move.

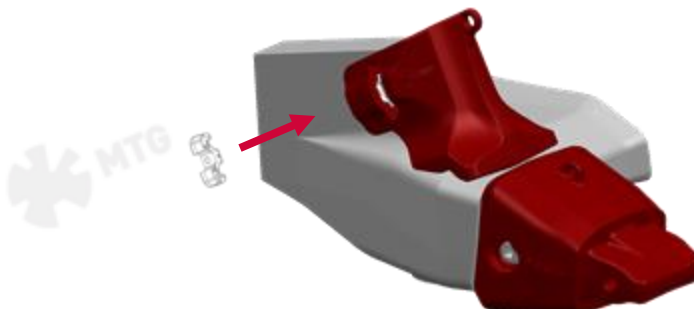

- 4.4** Place a 2 mm (1/16") shim at the front, between the weld-on base and the mechanical block as shown in the image. Then pull the weld-on base back using a pry bar or similar.

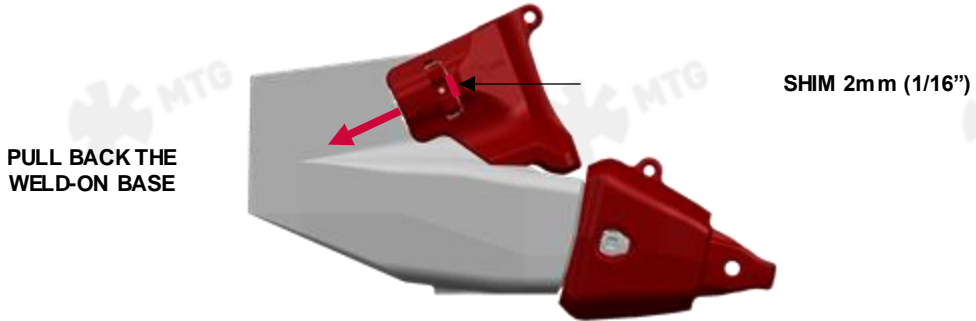

- 4.5** Before fixing the position of the base by means of tack welding, preheat the weld-on base and the lip to a temperature between 175°C and 200°C (347°F and 392°F) in a radius of 100 mm (4") around the welding area.

Insert a 1 mm (1/16") shim between the weld-on base and the guides of the shroud. Pull the weld-on base back with a pry bar or similar and while continue pulling the weld-on base, tack weld the base to the lip at the indicated spots.

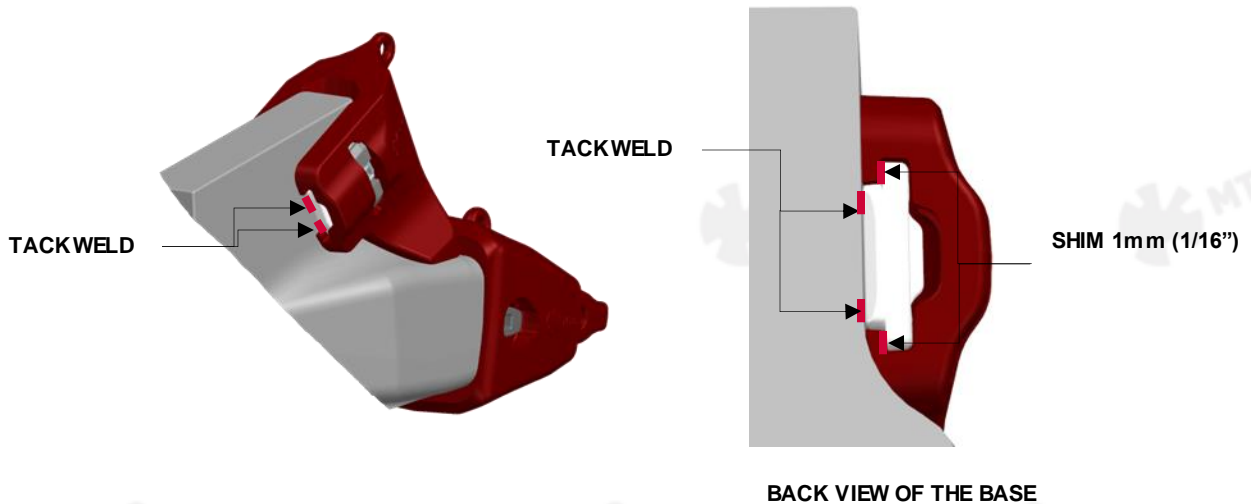

- 4.6** Remove the mechanical block and the shroud and tack weld the front of the weld-on base. At this time, proceed with the weld-on base welding.

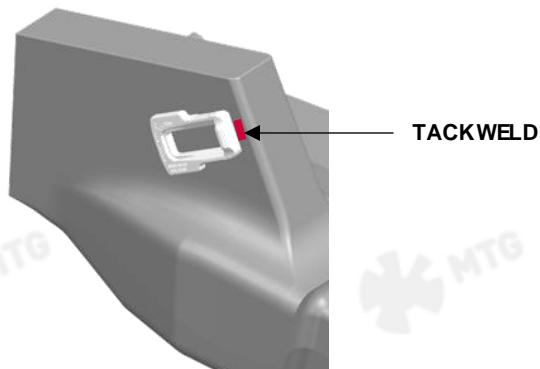

5. WELD-ON BASE WELDING

5.1 Before proceeding with the welding, verify that both base and lip are still at a temperature between 175°C and 200°C (347°F and 392°F) in an area of 100 mm (4") around the area to be welded. If necessary, preheat again to the indicated temperatures.

Proceed with the welding of the base in the indicated areas, filling the welding groove according to the color code indicated in the following figure. Do not weld outside the marked areas or exceed 250°C (482°F) during the welding process.

WELD-ON BASES FOR SIZES 5 and 7

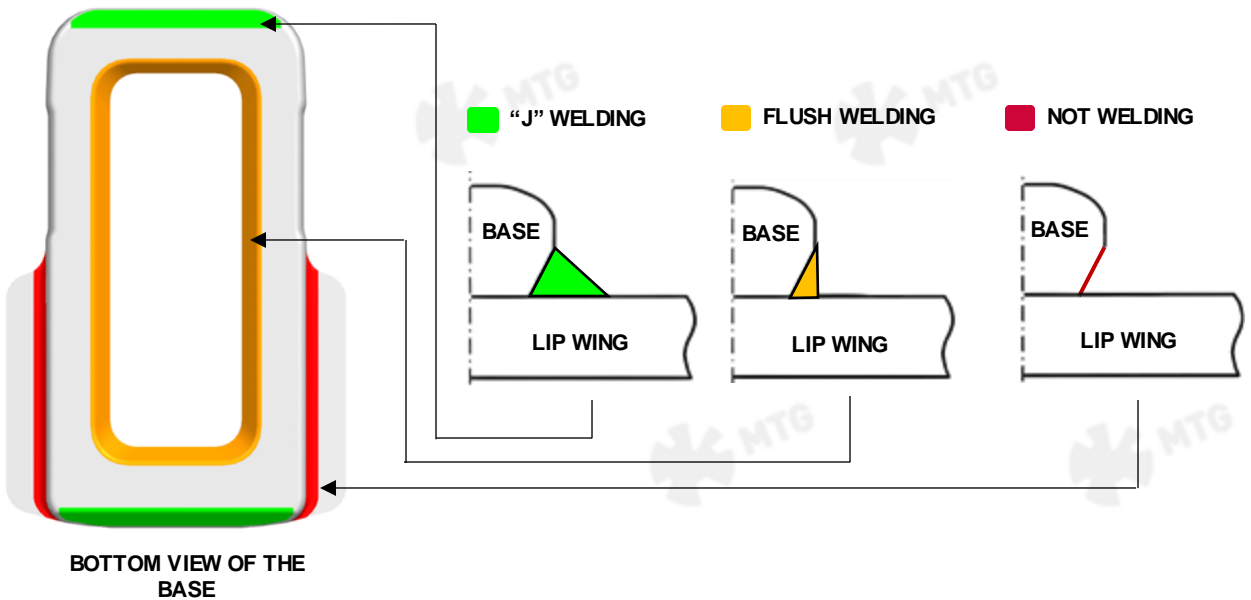

WELD-ON BASES FOR SIZE 1

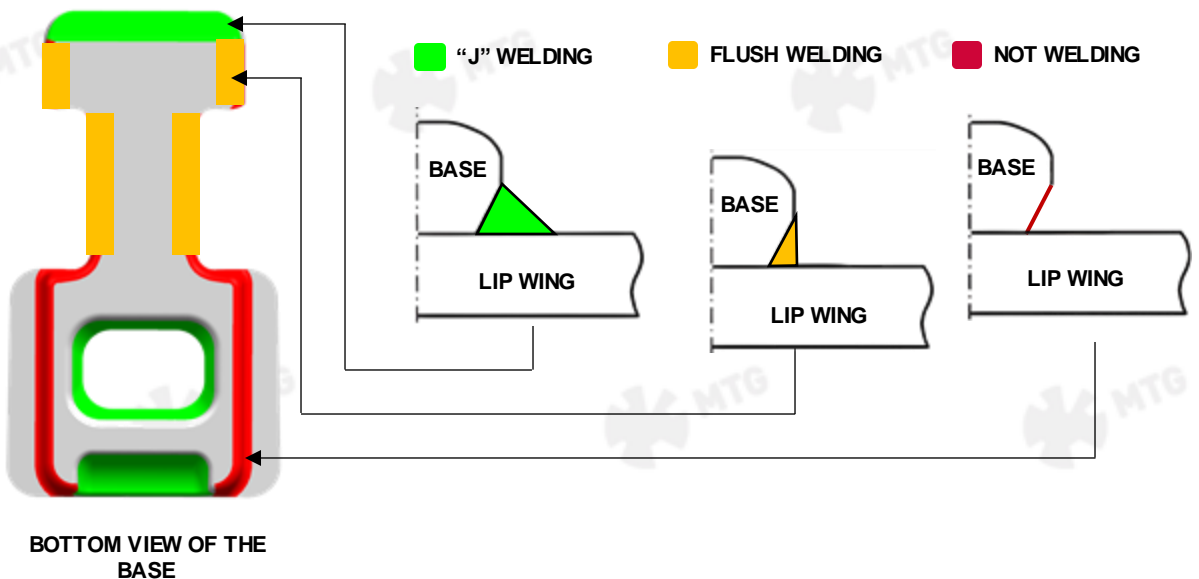

- 5.2** Once the welding is finished, it must be ground. After grinding, the surface must be free of rough areas and undulations associated with the arrangement of the welding beads. The edge of the weld must join in a regular and progressive way to the lip and the base with a minimum radius of 4mm (3/16").

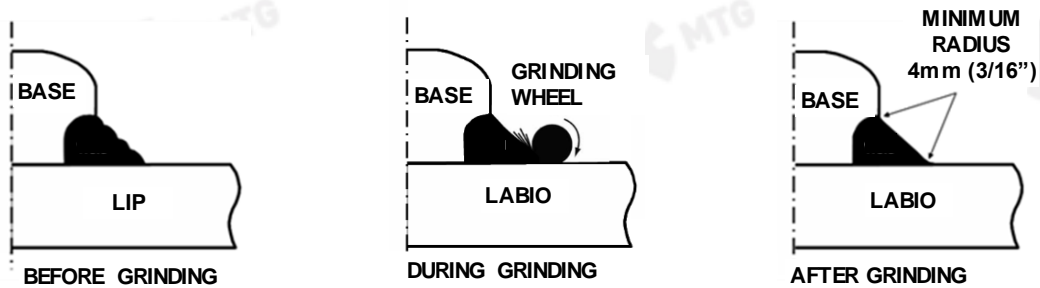

Grinding using electric or pneumatic grinders with discs up to 50mm (2") in diameter is recommended. HEADS OR ANGLE GRINDER ARE NOT RECOMMENDED FOR THIS TYPE OF WORK.

Grinding must be carried out with the outer part of the disc and not with the central part of it. The grinding direction must be perpendicular to the ends of the weld beads as shown in the figure.

For grinding of weld ends it is recommended to use conical grinding wheels. To ensure a good finish, the refining grain should not exceed 24 grit.

- 5.3** After grinding the welds, it is also recommended to carry out a peening of the weld toes or a high-frequency mechanical impact treatment as described in the document entitled "General recommendations for welding".
- 5.4** Finally, all welds should be subjected to a visual inspection and die penetrant, magnetic particles or similar, as described in the document entitled "General welding recommendations". Any weld cracks detected must be cleaned and repaired.
- 5.5** Carry out the same positioning and welding operation of the weld-on base at the opposite side of the lip.

6. INSTALLATION PROCEDURE

- 6.1** Slide the shroud through the weld-on base until it contacts the front surface of the lip side.

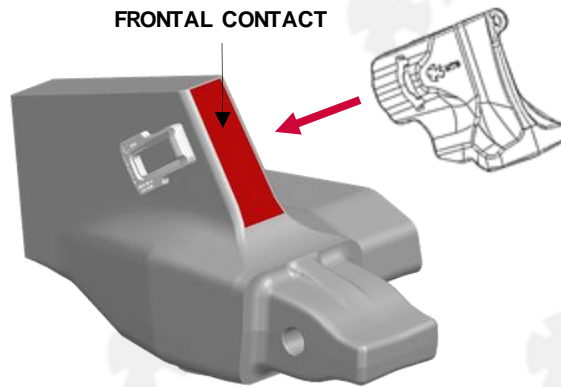

- 6.2** Insert the mechanical block into its housing between the shroud and the weld-on base, making sure that the "FRONT" text on the block faces away from the bucket. At this time, the shroud can no longer move.

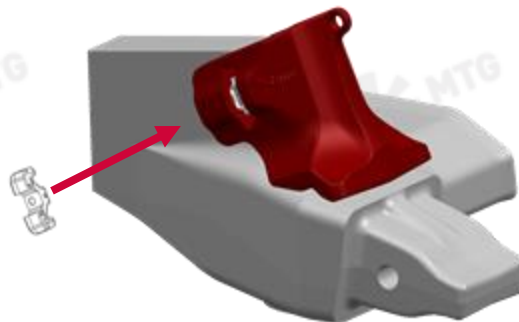

- 6.3** Insert the locking plate and slide it towards the inside bucket until its hole is concentric with the hole of the mechanical block. Then insert the bolt and tighten it to a maximum torque of 250 Nm (184 lbft). A 19mm (3/4") square drive is required. Finally insert the plug into the keyhole to protect it from dirt.

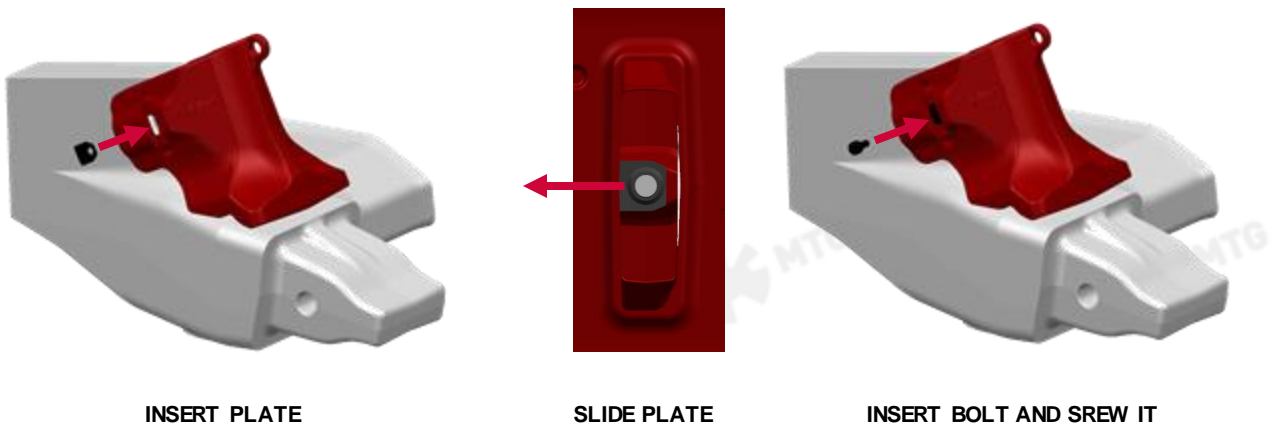

7. REMOVAL PROCEDURE

- 7.1** Clean the fins located behind the locking plate with a needle gun. Then, remove the cap from the bolt's head and unscrew it until it is loose. A 19mm (3/4") square socket is required. An impact gun can make the operation easier.

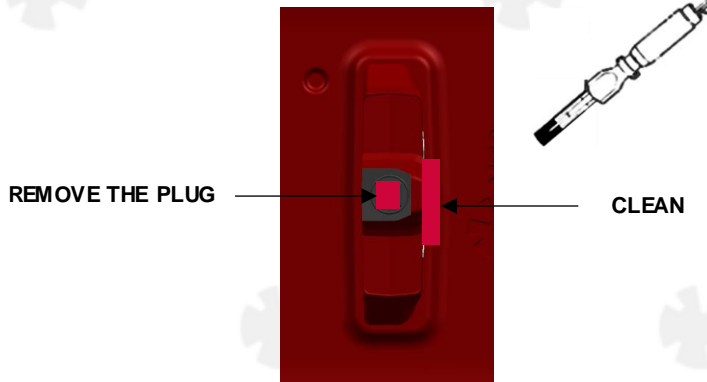

- 7.2** Remove the bolt, slide the locking plate forward and remove it. Additional cleaning may be required to ease the operation.

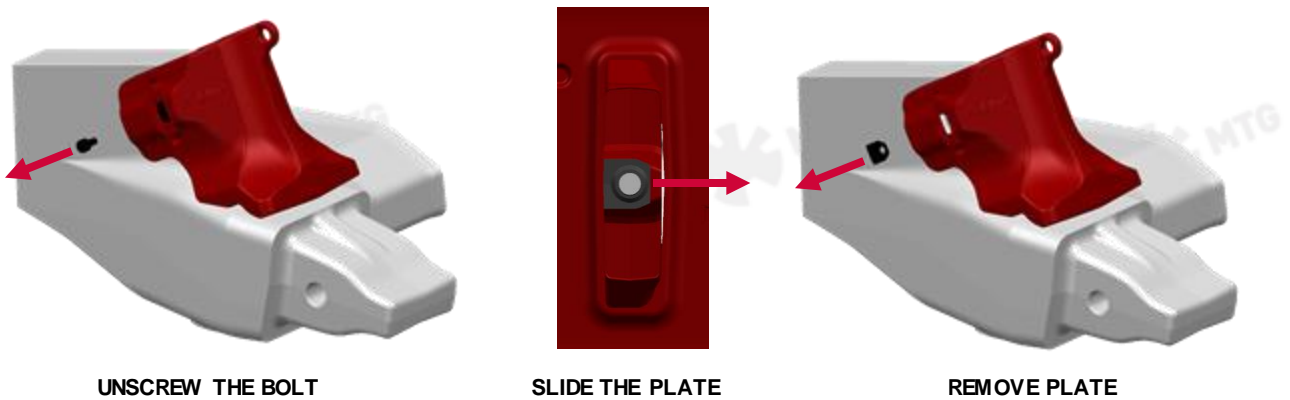

- 7.3** Extract the mechanical block with the help of a pry bar or similar. Alternating levering movement from both sides will make the operation easier.

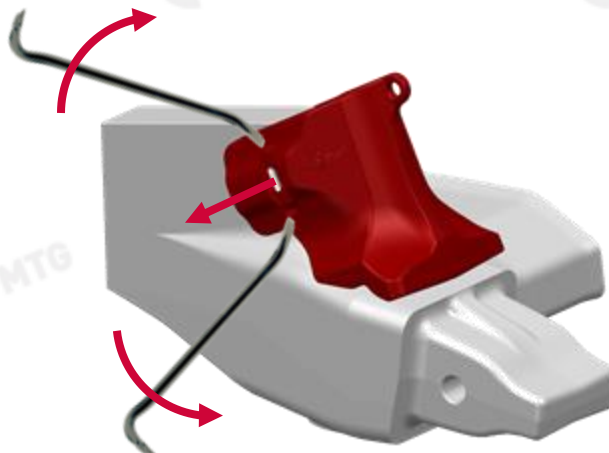

7.4 If required, weld a new lifting-lug to manipulate the shroud safely.

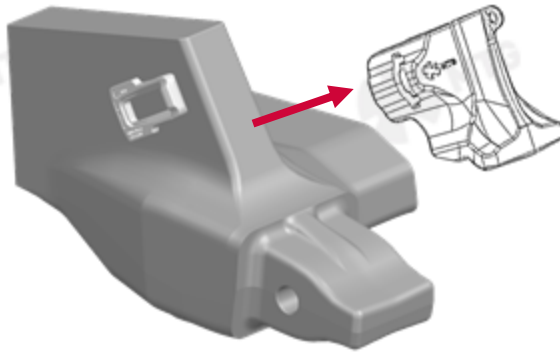



Service Instructions

The latest welding recommendations and assembly / disassembly instructions can be found online:

www.mtgcorp.com/manuals

Please contact Technical Services in case of questions:

technical.services@mtg.es



MTG HEADQUARTERS

Carrer d'Àvila, 45
08005 Barcelona (Spain)
(+34) 93 741 70 00
info@mtg.es

MTG NORTH AMERICA

4740 Consulate Plaza Drive
Houston, TX 77032 (USA)
+1 (281) 872 1500
info@mtgcorp.us

MTG AUSTRALIA

16 – 18 Thorpe Close
Welshpool, WA, 6106 (AUS)
+61 8 6248 6513
Info.australia@mtg.es