



**MTG**

No limits innovation



**INS.1.2.2**  
**TWINMET retrofit**  
**(solid tooth MJ square + DPN-HD)**  
Installation procedure

## DISCLAIMER

### © MTG, all rights reserved

The brands identified with an asterisk do not belong to METALOGENIA S.A. and this organization refers to them only to identify the destination of its products, without there being any relationship between METALOGENIA S.A. and the legitimate owners of any such brands.

**Copy right:** It is strictly forbidden for any person not belonging to MTG to distribute all or any part of the material set out in this document unless they are authorized to do so.

**Liability:** To ensure the correct use and handling of the MTG products without risk, please carefully read the corresponding service instructions set out on the MTG website. MTG will not be held liable for damages, loss, injury, or death arising from incorrect use or failure to heed the provisions of this guide. Similarly, MTG will not be held liable for damages caused due to the faulty installation or handling of its products. MTG likewise declines all liability for recommendations related to the use or handling of MTG products set out in documents not expressly authorized by MTG.

MTG is the sole legitimate owner of the trademarks that identify its products. Trademarks and/or drawings marked with an asterisk (\*) are not the property of MTG and are mentioned and/or shown for the sole purpose of identifying the destination of MTG products.

## 1. SAFETY

The practices described in this manual can be taken as guidelines for operating safely in many conditions and in addition to the safety standards that are current and enforceable in your area or region.

Your safety and the safety of third parties is the result of putting into practice your knowledge of the correct operational procedures.

Attention, when performing the work described in these instructions, always work safely and use the personal protection elements required to minimize or avoid injury. Always wear:



**HARD  
HAT**



**SAFETY  
GLASSES**



**EAR  
PROTECTION**



**STEEL TOED  
BOOTS**



**PROTECTION  
GLOVES**

To avoid eye injury, always wear safety goggles or a protective mask when using any equipment, hammer or similar tool. When equipment is under pressure or when objects are struck, chips or other debris can be thrown out. Make sure no one gets hurt by the debris that is fired before applying pressure or hitting an object. Wear eye protection that complies with ANSI Z87.1 and OSHA standards. Also wear hearing protection and gloves.

Lifting a heavy object can cause serious or fatal injury. DO NOT exceed the maximum rated capacity of lifting and positioning devices: Stay away from the area under a suspended load.

Make sure that the chain is not damaged and that the load is always balanced.



**LIFTING  
LUG**

## 2. INSTALLATION PROCEDURE

- 2.1** Insert the pin into its housing in the nose on either side. Make sure the pin shafts are retracted.

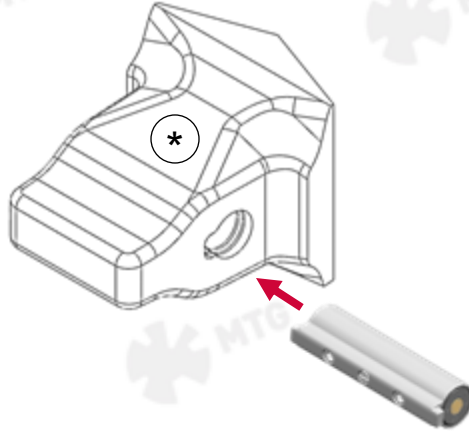

- 2.2** Insert the tooth into the nose with the help of the lifting lug and a crane.

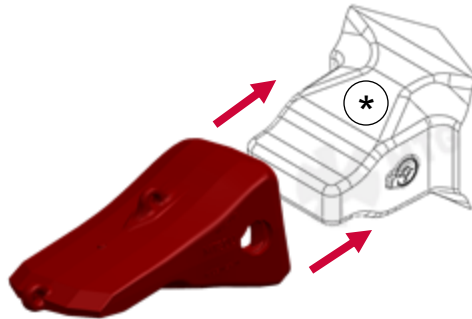

- 2.3** Extend the shafts by turning the bolt clockwise with a 14mm (9/16") hex head wrench. The rotational movement of the bolt will protrude the shaft on one of the sides and when it reaches its maximum extension, the one on the opposite side will begin to protrude. Once the shafts have been extended on both sides, place the plugs in the hexagonal bolt holes to prevent dirt from entering.

RETRACTED SHAFTS

EXTENDED SHAFTS

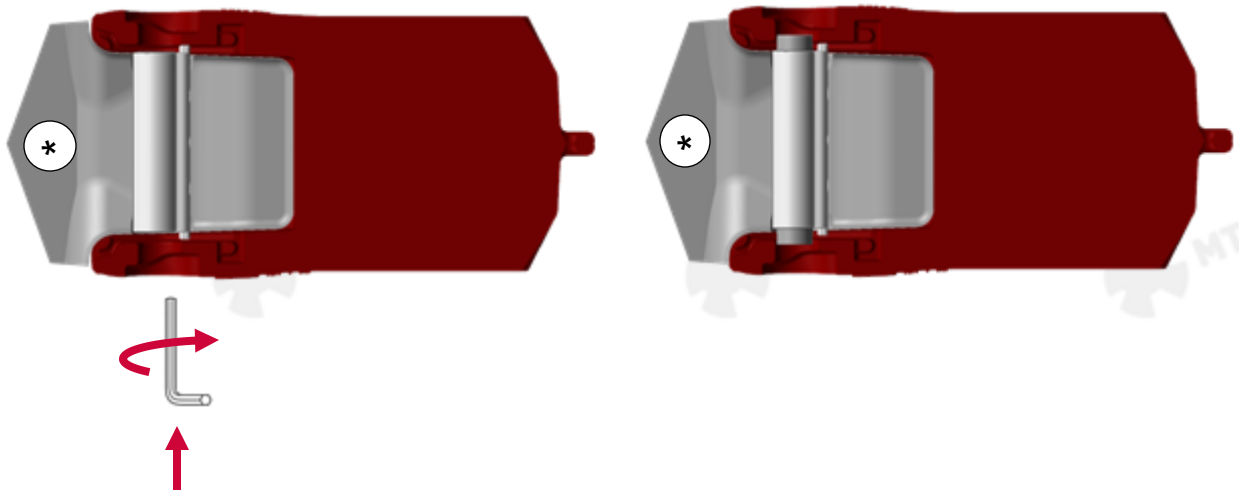

### 3. REMOVAL PROCEDURE

- 3.1** Extract the plug from the housing for the hexagonal key of the bolt on the side of the pin to be operated and clean the remains of dirt that may have remained in the hole.

Retract the shafts by turning the bolt counterclockwise with a 14mm (9/16") hex head wrench. The rotational movement of the bolt will retract the shaft on one side and when fully retracted the shaft on the opposite side will begin to retract.

EXTENDED SHAFTS

RETRACTED SHAFTS

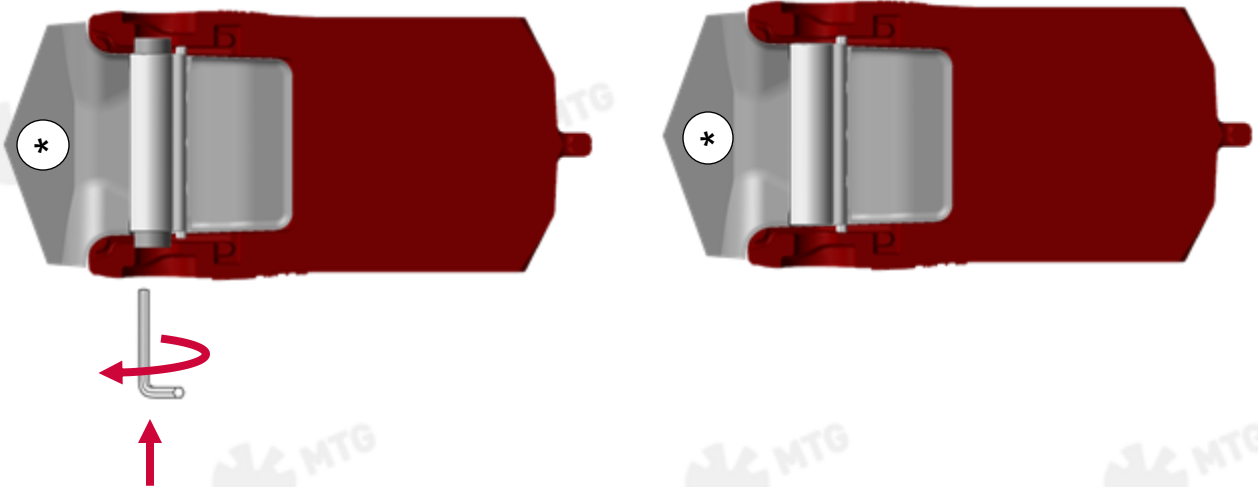

- 3.2** Extract the tooth with the help of a crane.

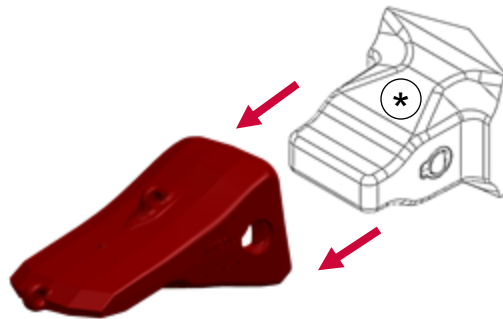

- 3.3** Extract the pin and check if it is in good conditions to be used again or if it should be replaced.

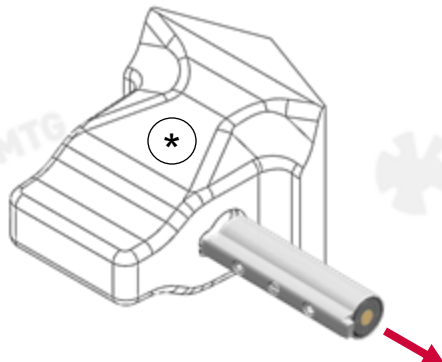



## Service Instructions

The latest welding recommendations and assembly / disassembly instructions can be found online:

[www.mtgcorp.com/manuals](http://www.mtgcorp.com/manuals)

Please contact Technical Services in case of questions:

[technical.services@mtg.es](mailto:technical.services@mtg.es)



---

### MTG HEADQUARTERS

Carrer d'Àvila, 45  
08005 Barcelona (Spain)  
(+34) 93 741 70 00  
info@mtg.es

### MTG NORTH AMERICA

4740 Consulate Plaza Drive  
Houston, TX 77032 (USA)  
+1 (281) 872 1500  
info@mtgcorp.us

### MTG AUSTRALIA

16 – 18 Thorpe Close  
Welshpool, WA, 6106 (AUS)  
+61 8 6248 6513  
Info.australia@mtg.es