



MTG

No limits innovation



INS.1.1.1

STARMET Tooth System

Installation procedure

DISCLAIMER

© MTG, all rights reserved

The brands identified with an asterisk do not belong to METALOGENIA S.A. and this organization refers to them only to identify the destination of its products, without there being any relationship between METALOGENIA S.A. and the legitimate owners of any such brands.

Copy right: It is strictly forbidden for any person not belonging to MTG to distribute all or any part of the material set out in this document unless they are authorized to do so.

Liability: To ensure the correct use and handling of the MTG products without risk, please carefully read the corresponding service instructions set out on the MTG website. MTG will not be held liable for damages, loss, injury, or death arising from incorrect use or failure to heed the provisions of this guide. Similarly, MTG will not be held liable for damages caused due to the faulty installation or handling of its products. MTG likewise declines all liability for recommendations related to the use or handling of MTG products set out in documents not expressly authorised by MTG.

1. SAFETY

The practices described in this manual can be taken as guidelines for operating safely in many conditions and in addition to the safety standards that are current and enforceable in your area or region.

Your safety and the safety of third parties is the result of putting into practice your knowledge of the correct operational procedures.

Attention, when performing the work described in these instructions, always work safely and use the personal protection elements required to minimize or avoid injury. Always wear:



To avoid eye injury, always wear safety goggles or a protective mask when using any equipment, hammer or similar tool. When equipment is under pressure or when objects are struck, chips or other debris can be thrown out. Make sure no one gets hurt by the debris that is fired before applying pressure or hitting an object. Wear eye protection that complies with ANSI Z87.1 and OSHA standards. Also wear hearing protection and gloves.

Lifting a heavy object can cause serious or fatal injury. DO NOT exceed the maximum rated capacity of lifting and positioning devices: Stay away from the area under a suspended load.



LIFTING LUG

Make sure that the chain is not damaged and that the load is always balanced.

2. INSTALLATION PROCEDURE

2.1 POLIURETHANE RETAINER

2.1.1 Insert the retainer on its housing at the adapter nose. The rigid polyurethane must be facing out.

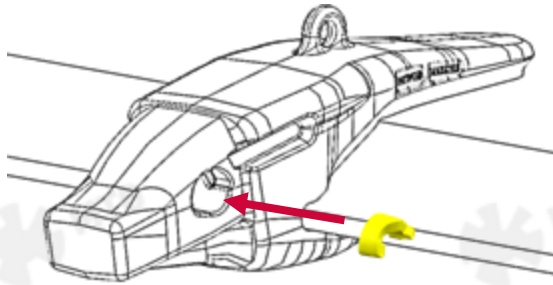

2.1.2 If required, insert the wear cap before installing the tooth.

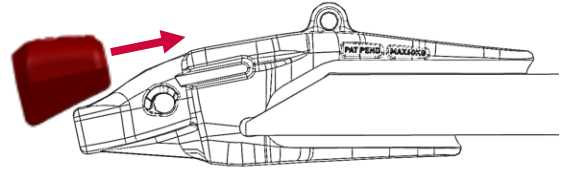

2.1.3 Insert the tooth into the adapter nose.

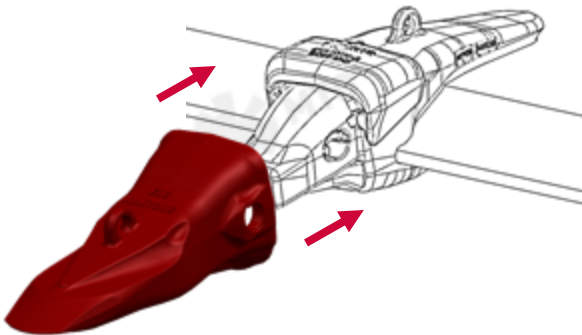

2.1.4 Insert the pin into the tooth's hole until it stops.

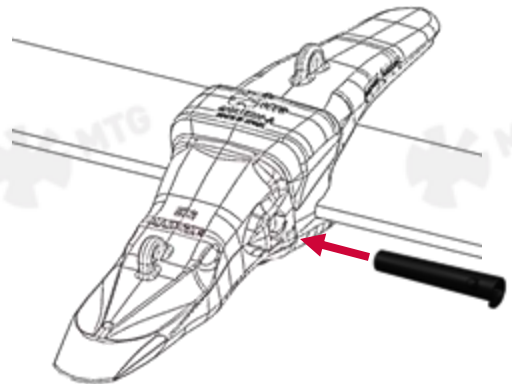

2.1.5 By means of the removal tool, turn the pin 90° clockwise. Then insert the protective plug into the square pin hole to prevent it from dirt.

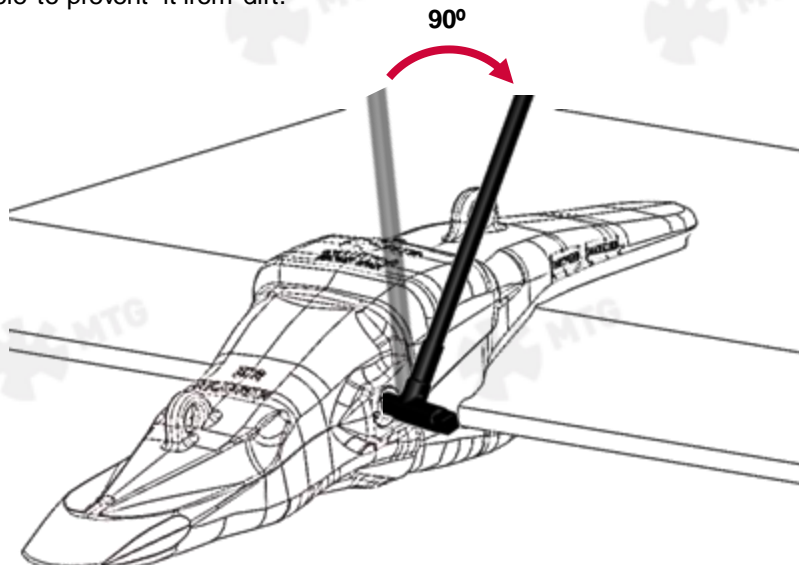

2.2 METALLIC RETAINER

2.2.1 Insert the retainer on its housing at the adapter nose.

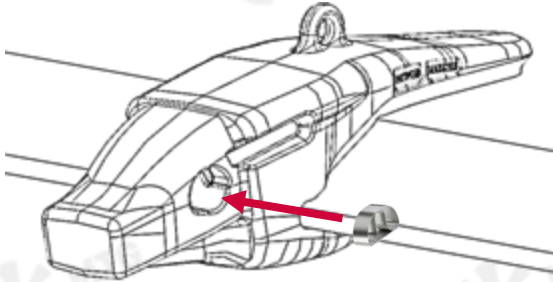

2.2.2 If required, insert the wear cap before installing the tooth.

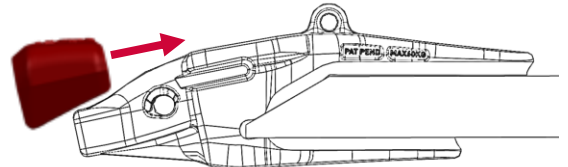

2.2.3 Insert the tooth into the adapter nose.

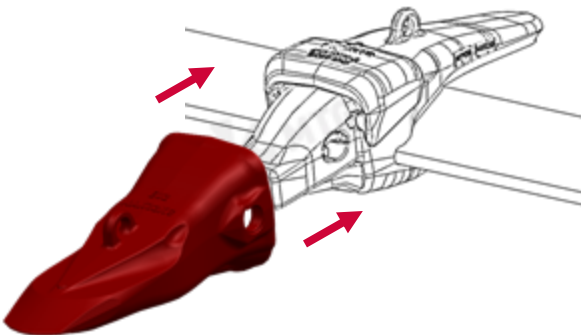

2.2.4 Point the pin against the retainer, aligning the chamfer of the pin against the edge of the retainer.

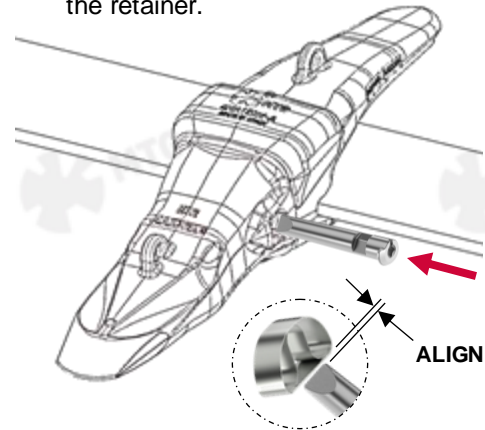

2.2.5 Insert the pin by pushing and rocking back and forth at the same time with the tool to ease its introduction.

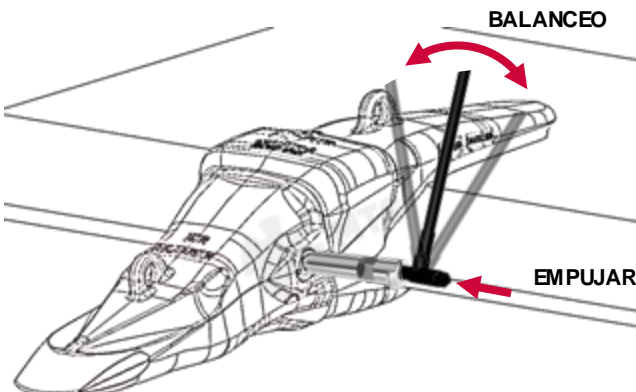

2.2.6 Once the pin reaches its final position a "click" sound will be heard. That means that the pin is locked. After that, insert the protective plug into the square pin hole to prevent it from dirt.

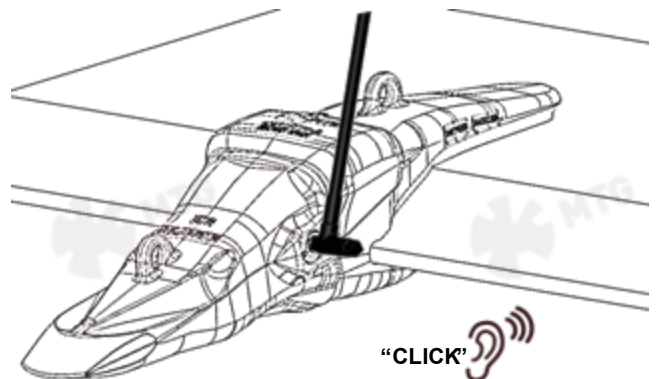

3. REMOVAL PROCEDURE (BOTH RETAINERS)

- 3.1** Remove the protective plug from its housing and turn the pin 90° anticlockwise by means of the removal tool. If the turning becomes hard, do not force the tool and proceed with several sway movements to break the fines.

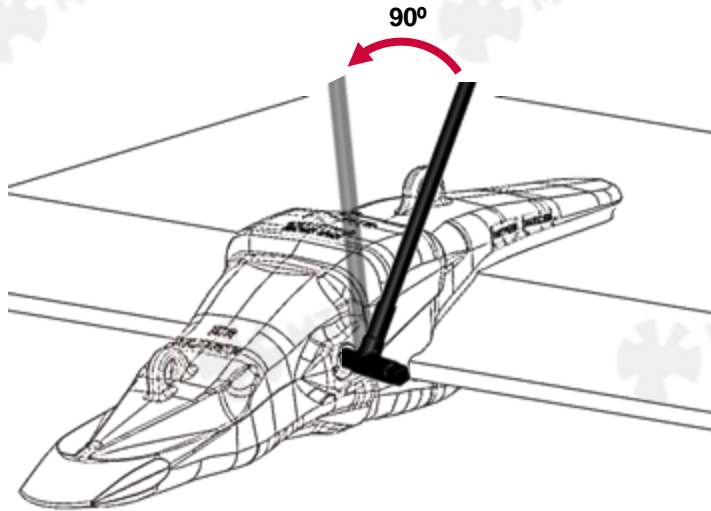

- 3.2** Take the pin off by slightly hitting the pin's opposite side.

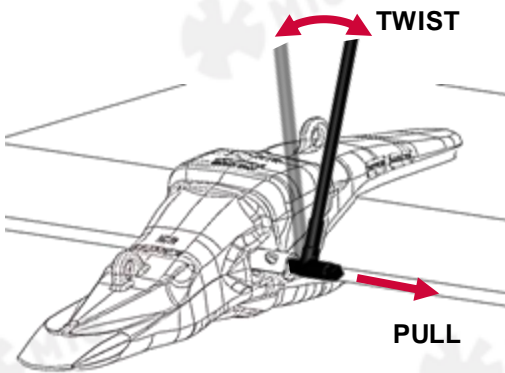

- 3.3** Remove the tooth from the adapter.

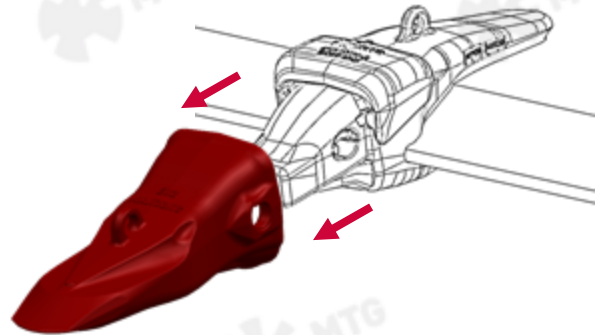

- 3.4** Check the status of the wear cap, if it was installed, and replace it if necessary.

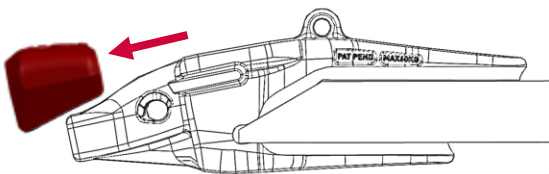

- 3.5** Take the retainer off and replace it by a new one.

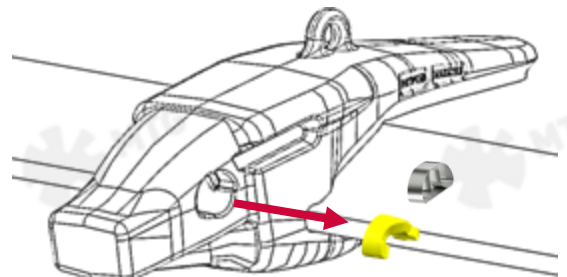



Service Instructions

The latest welding recommendations and assembly / disassembly instructions can be found online:

www.mtgcorp.com/manuals

Please contact Technical Services in case of questions:

technical.services@mtg.es



MTG HEADQUARTERS

Carrer d'Àvila, 45
08005 Barcelona (Spain)
(+34) 93 741 70 00
info@mtg.es

MTG NORTH AMERICA

4740 Consulate Plaza Drive
Houston, TX 77032 (USA)
+1 (281) 872 1500
info@mtgcorp.us

MTG AUSTRALIA

16 – 18 Thorpe Close
Welshpool, WA, 6106 (AUS)
+61 8 6248 6513
Info.australia@mtg.es